

8 7 6 5 4 3 2 1

D

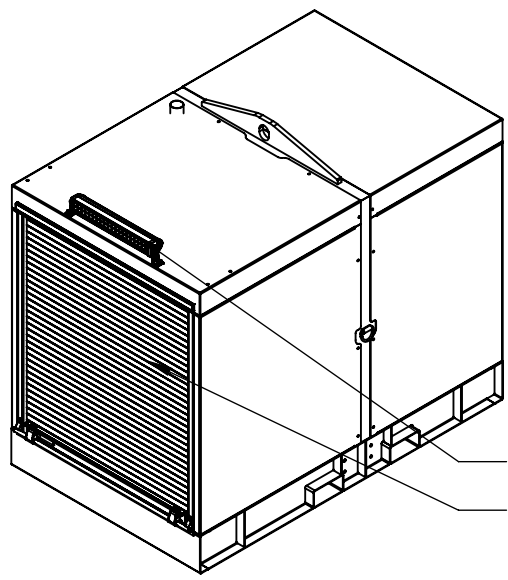

REAR SCENE LIGHT  
ROLL-UP DOOR ACCESS

LIFTING BAR  
DEF (TIER 4 ONLY) ACCESS  
BATTERY/CHARGER ACCESS  
FORKLIFT TUBE POCKETS

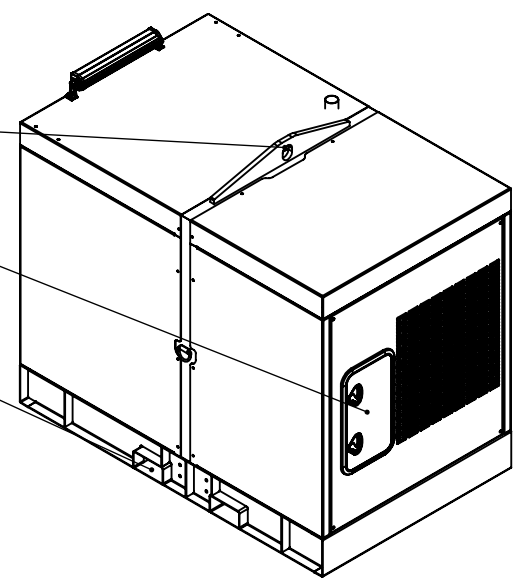

D

C

C

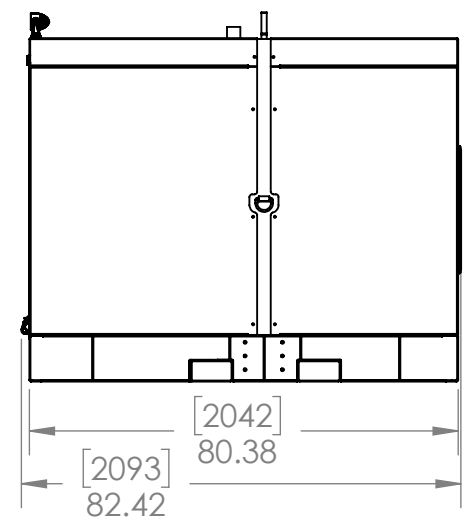
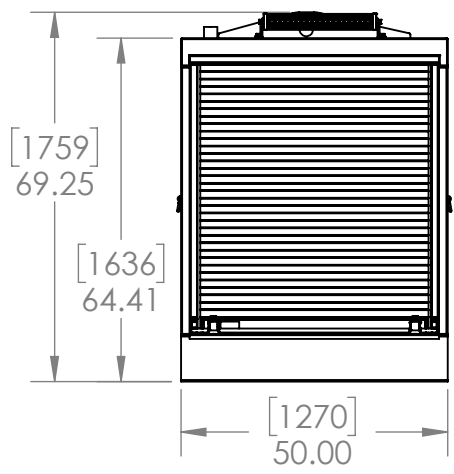

B

NOTES:

- SYSTEM WEIGHT: 3600 LBS (1633 KG)

A

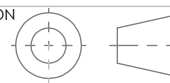
UNLESS OTHERWISE SPECIFIED:		NAME	DATE	 <b>KASE</b> PUMPING SYSTEMS
DIMENSIONS ARE IN INCHES [mm] TOLERANCES: FRACTIONAL ± 1/8 ANGULAR: MACH ± 0.5 BEND ± 1 TWO PLACE DECIMAL ± 0.01 THREE PLACE DECIMAL ± 0.005		DRAWN BY	KVC	
INTERPRET GEOMETRIC TOLERANCING PER: ANSI/ASME Y14.5		ENG APPR.		TITLE: <b>GENERAL LAYOUT                  OTTER STANDARD</b>
MATERIAL		PART NUM		
FINISH		PROPRIETARY AND CONFIDENTIAL		
PROJECTION		THE INFORMATION CONTAINED IN THIS DRAWING IS THE SOLE PROPERTY OF KASE PUMPING SYSTEMS LLC. ANY REPRODUCTION IN PART OR AS A WHOLE WITHOUT THE WRITTEN PERMISSION OF KASE PUMPING SYSTEMS LLC IS STRICTLY PROHIBITED.		
		SIZE	DWG. NO.	REV
		A	OPSS-GL	
		SCALE 1:36	SHEET 1 OF 1	

A

8 7 6 5 4 3 2 1