

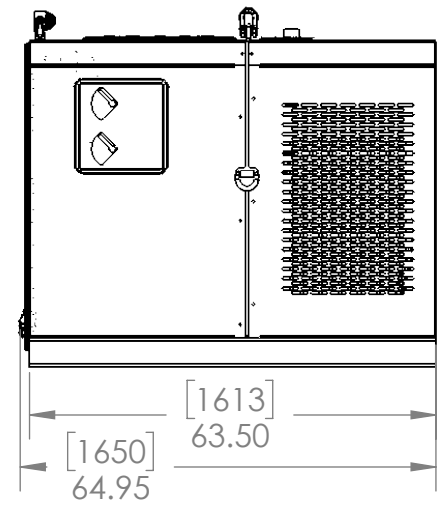

LIFTING EYE
 FUEL FILL HATCH
 SCENE LIGHT
 BATTERY AND HYDRAULIC TANK FILL ACCESS HATCH
 BATTERY CUT-OFF AND SMART CHARGER ACCESS
 FORK POCKETS

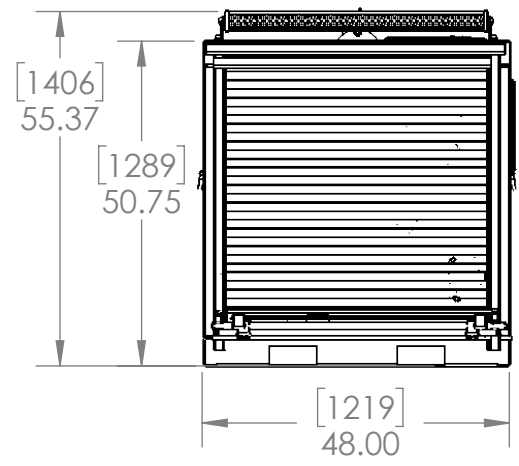
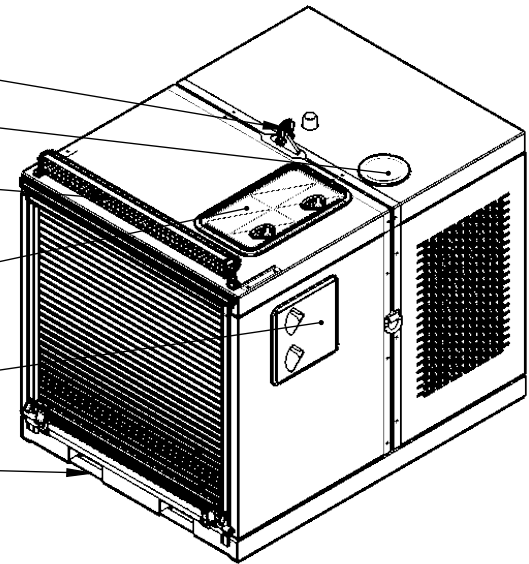

NOTES:

- SYSTEM WEIGHT: 2200 LBS (1000 KG)

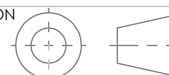
UNLESS OTHERWISE SPECIFIED:		NAME	DATE	 KASE PUMPING SYSTEMS
DIMENSIONS ARE IN INCHES [mm] TOLERANCES: FRACTIONAL ± 1/8 ANGULAR: MACH ± 0.5 BEND ± 1 TWO PLACE DECIMAL ± 0.01 THREE PLACE DECIMAL ± 0.005		DRAWN BY	KVC	
INTERPRET GEOMETRIC TOLERANCING PER: ANSI/ASME Y14.5		ENG APPR.		TITLE:
MATERIAL		PART NUM		GENERAL LAYOUT OTTER MINI
FINISH		PROPRIETARY AND CONFIDENTIAL		SIZE DWG. NO. REV
PROJECTION		THE INFORMATION CONTAINED IN THIS DRAWING IS THE SOLE PROPERTY OF KASE PUMPING SYSTEMS LLC. ANY REPRODUCTION IN PART OR AS A WHOLE WITHOUT THE WRITTEN PERMISSION OF KASE PUMPING SYSTEMS LLC IS STRICTLY PROHIBITED.		A A
		SCALE 1:30		SHEET 1 OF 1